

CUSTOMER

CAN ART STD.

DIE No.

ES05806

REV. No.

1

DESCRIPTION

ALUM ANGLE 3/16 x 2 x 2 - 1/2"

CUSTOMER PART No.

PROPOSAL No.
S-52808

NOTE: BREAK ALL CORNERS WITH 0.015" (.38 MM) RADIUS UNLESS OTHERWISE NOTED. STANDARD TOLERANCES TO APPLY UNLESS OTHERWISE SPECIFIED.

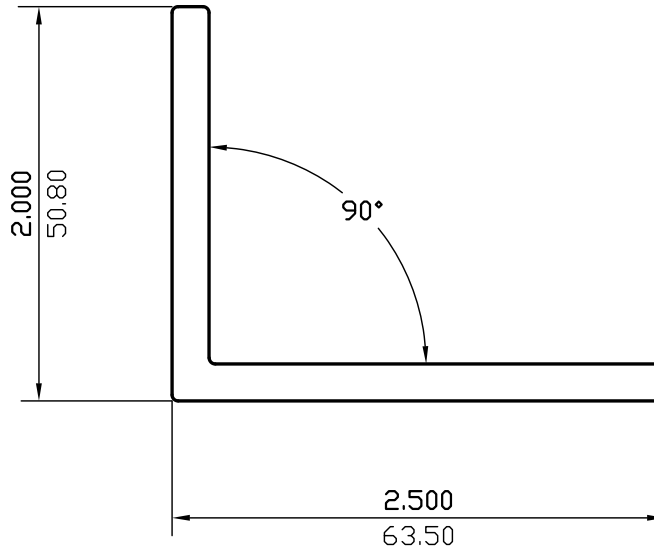

WALL THICKNESS 0.188 (4.78) EXCEPT AS SHOWN

DATE	REV	DESCRIPTION	BY
03/20/23	1	REMOVED EXPOSED SURFACES AND ALLOY	JASON
EST.AREA	0.810	IN. ²	EST.AREA 522.475
			MM. ²
EST.WT.	0.972	LBS/FT.	EST.WT. 1.446
			KG/M.
EST.PER.	8.920	IN.	EST.PER. 226.572
			MM.
OUT PER.		IN.	OUT PER.
			MM.
C.C.D.	3.249	IN.	C.C.D. 82.517
			MM.
FINISH	M/F		ALLOY
CKD BY	FACTOR 9	SCALE 1:1	DWN BY J.C. DATE 10/16/2004

CAN ART

ALUMINUM EXTRUSION INC.

428 JUTRAS DRIVE S.
WINDSOR, ON N8N 5C5
TEL. NO. (519) 727-4399
FAX NO. (519) 727-6434
WEB: www.canart.com

THIS DRAWING IS NOT NECESSARILY A COPY OF YOUR ORIGINAL. PLEASE APPROVE DIMENSIONS AND TOLERANCES INDICATED. CAN ART ASSUMES NO RESPONSIBILITY EITHER TECHNICAL OR LEGAL FOR HAVING THIS SHAPE MADE. THE CUSTOMER AGREES TO FULLY PROTECT CAN ART ALUMINUM FROM CLAIMS OF OTHERS RESULTING FROM THIS SHAPE.

SIGNED: _____ DATE: _____